



Toyota's Advanced Vehicles

Robert Wimmer

Environmental Research Manager

Toyota Motor North America

MIT LFEE Endicott House Symposium

August 4, 2005

Overview

- The problem and Toyota's response
- Our hybrids & their technology
- Fuel economy vs. fuel savings
- Toyota's Fuel Cell Hybrid Vehicle (FCHV)
- The fuel cell challenge
- Conclusions

Why Worry?

- EIA 2025 Projections
 - Petroleum
 - World use up by at least 40%
 - US imports up by at least 50%
 - CO₂ Emissions
 - US total up by at least 40%
 - Transportation up by at least 40%
- Oil production peaking by mid-century

Petroleum Use

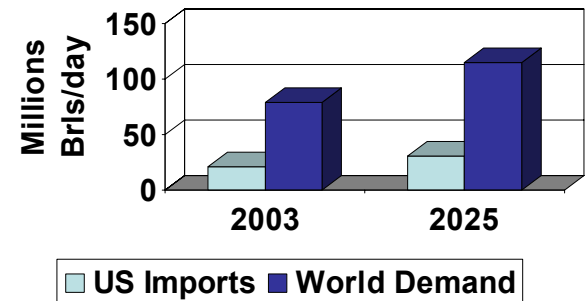

US CO₂ Emissions

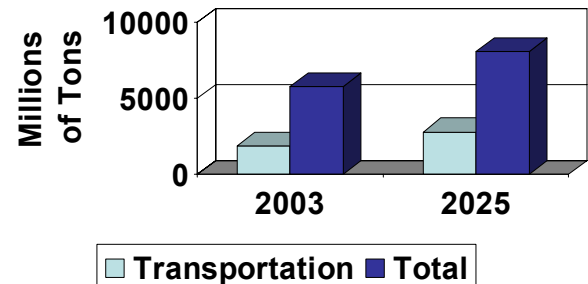

Vehicles per 1000 People

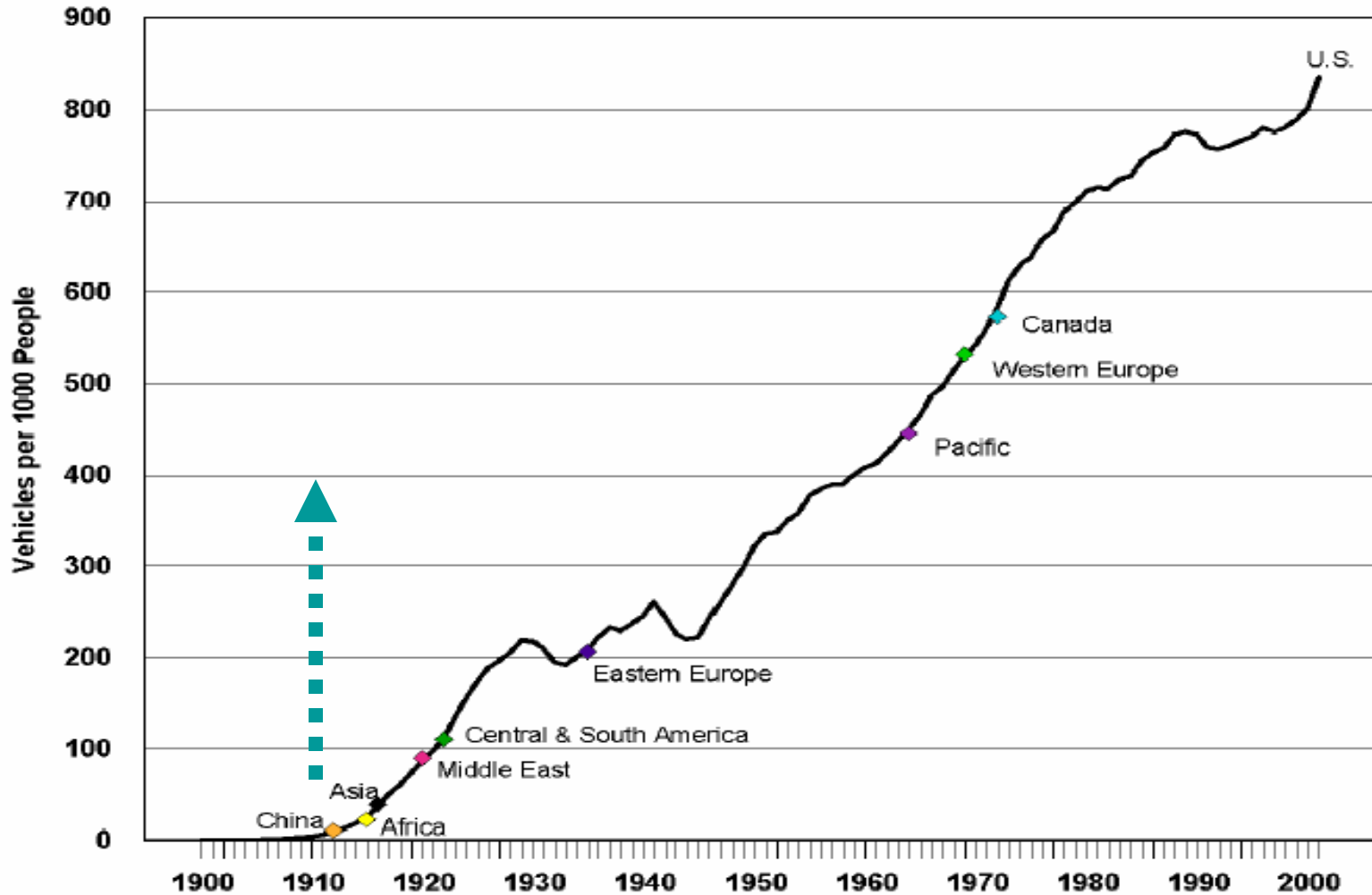

Societal Responsibility

“Toyota and the other automakers will not survive the 21st Century unless we find ways to limit the car’s impact on our earth.”



Fujio Cho

President

Toyota Motor Corporation

Enlightened Self-Interest

**Expand personal mobility
+ Minimize impact on planet
= Sustainable Mobility**

Toyota's Approach to Sustainable Mobility

- Near Term
 - Clean and efficient conventional powertrains
 - Use of fuel saving technologies
 - VVTI, 6 & 7 speed transmissions, DI, weight reduction & low friction designs
 - **Hybridization**
- Long Term
 - HCCI
 - Bio fuels
 - **Fuel Cell**

What Does the Market Want

A significant and growing percentage of customers indicate a willingness to buy an environmentally friendly vehicle

IF, and ONLY if, attributes meet or exceed competitive offerings at a reasonable cost

Current Toyota Hybrids



Toyota Prius



Toyota Highlander Hybrid



Lexus RX400h

Future Hybrids



'07 Lexus GS 450h

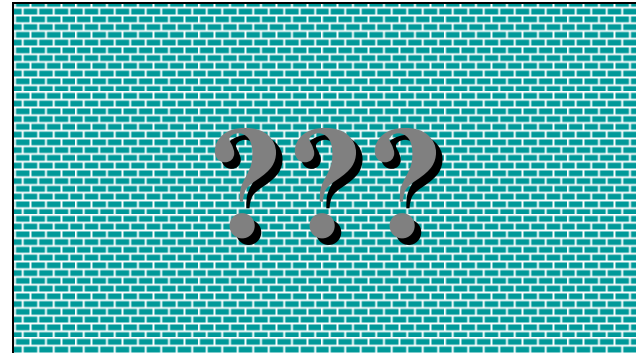

'07 Camry Hybrid

Hybrid Benefits

- Improved Fuel Economy
- Lower Emissions
- Improved Performance
- ***Combinations of the above***

Economy



8/16/2005

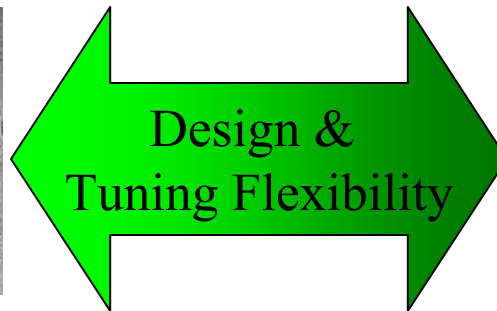

Performance



10

Hybrid Synergy Drive (HSD)

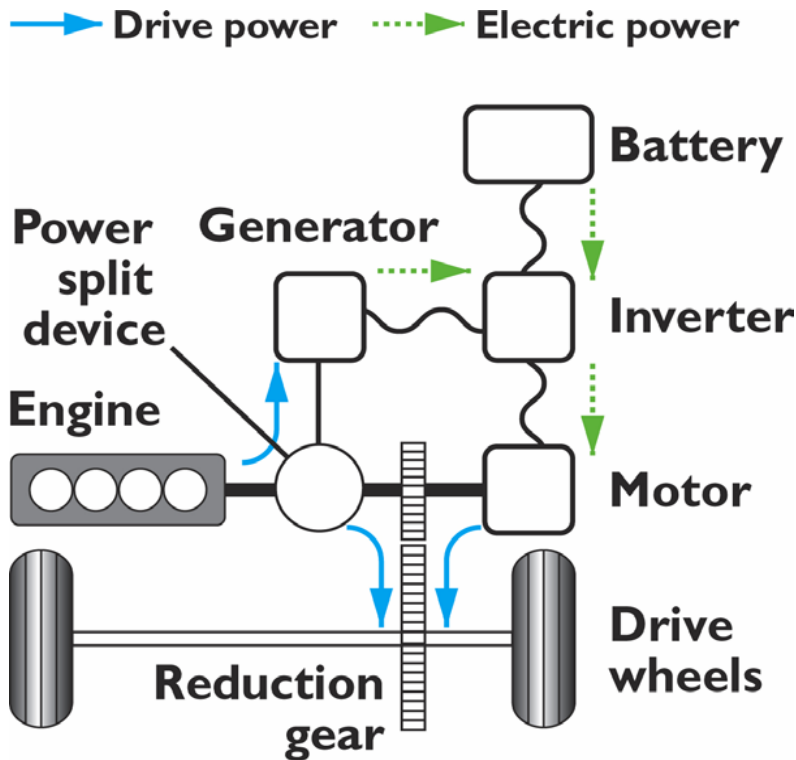

HSD consists of

- High efficiency gas engine
- Planetary gear power split device
- AC synchronous generator
- High voltage AC-DC inverter
- Nickel-metal hydride battery
- Permanent magnet AC motor

Hybrid Driving Modes

Low Speed

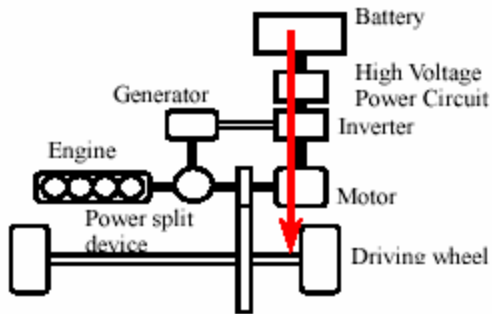

Normal Driving

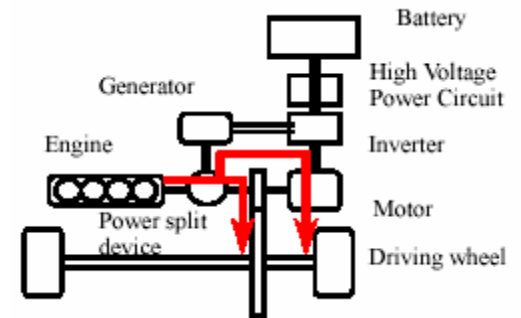

Sudden Acceleration

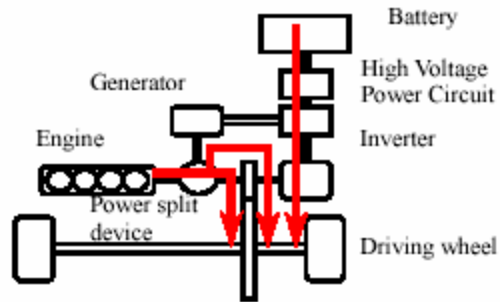

Battery Charging

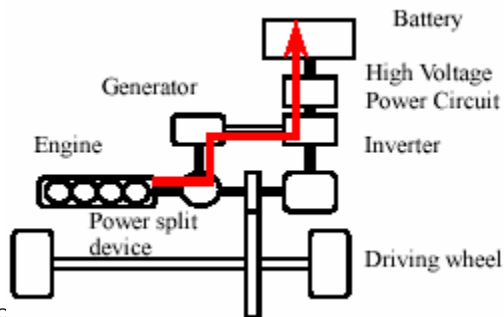

Regeneration

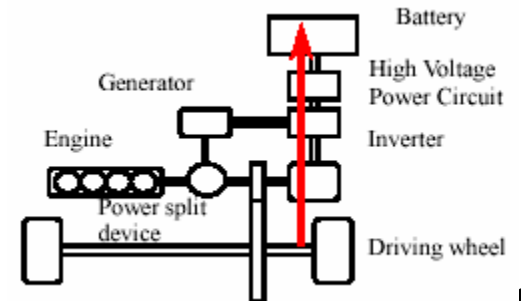

Prius History – Continuous Improvement

Model Years	<u>1998-2000</u> *	<u>2001-2003</u>	<u>2004-</u>
City Label FE	43	52	60
Highway Label FE	41	45	51
Combined Label FE	42	48	55
0-60 Acceleration	14.5	12.5	10.5
Emissions	LEV	SULEV	AT-PZEV
Size Class	Sub-Compact	Compact	Mid-size
		Minor Change	Model Change

* Japan only

More to come!

RX400h Comparison with V8 Powered SUVs

<u>Vehicle</u>	<u>0-60 sec*</u>	<u>HP</u>	<u>Fuel Economy</u> <u>(City/Highway)</u>	<u>Price</u>
Lexus RX400h	6.9	268	31/27	\$49,185
BMW X5 4.4i	7.1	315	16/22	\$53,495
Infiniti FX45	6.3	315	15/19	\$46,060
Mercedes Benz ML500	6.7	302	14/19	\$49,220
Porsche Cayenne S	7.7	340	14/18	\$57,195
Volkswagen Touareg V8	7.2	310	14/18	\$44,915

* Car & Driver Published Figures

Comparable
Performance

Significant
improvement
in fuel efficiency

No hybrid
“price premium”

Comparison of Fuel Economy

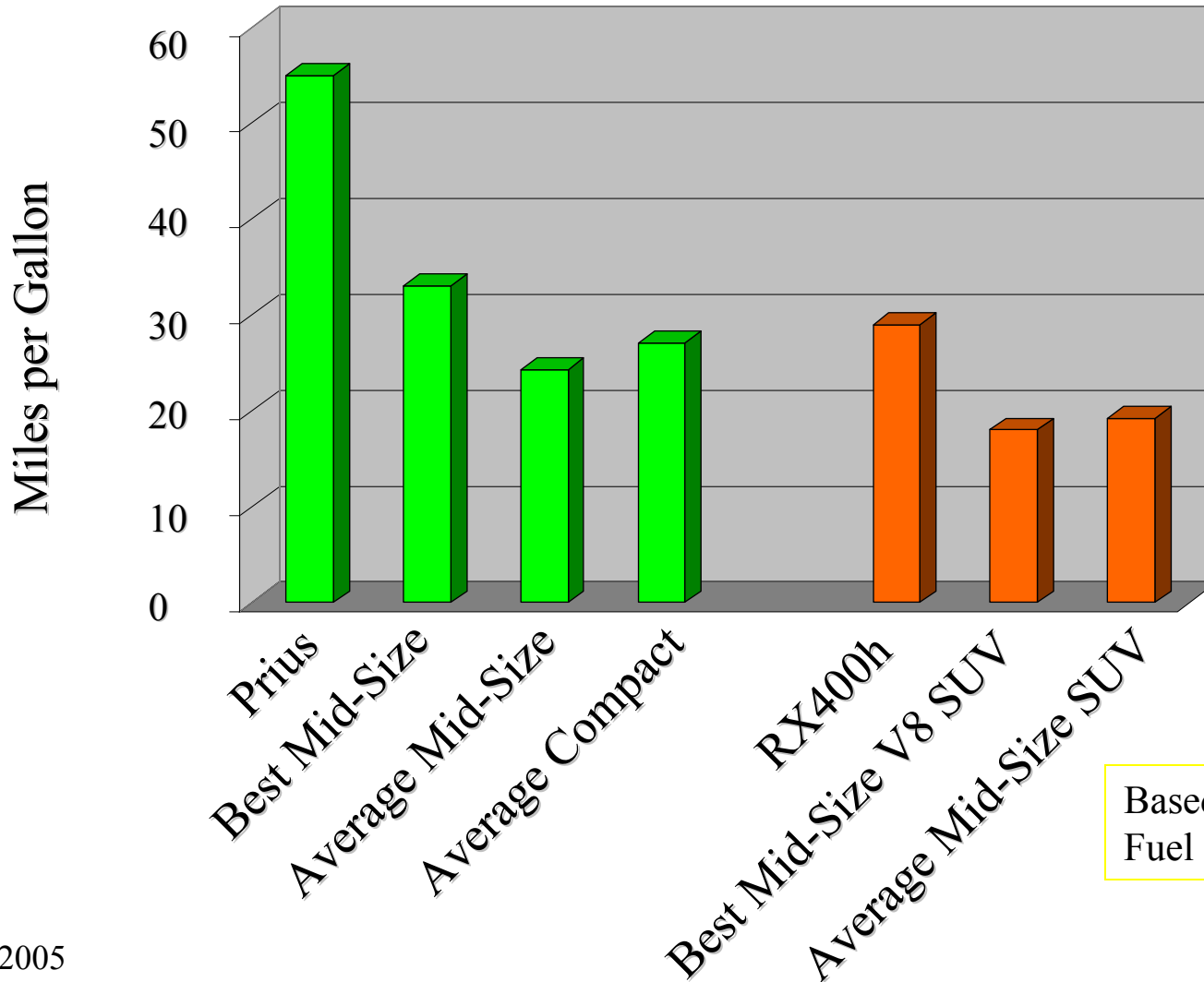

Annual Fuel Savings

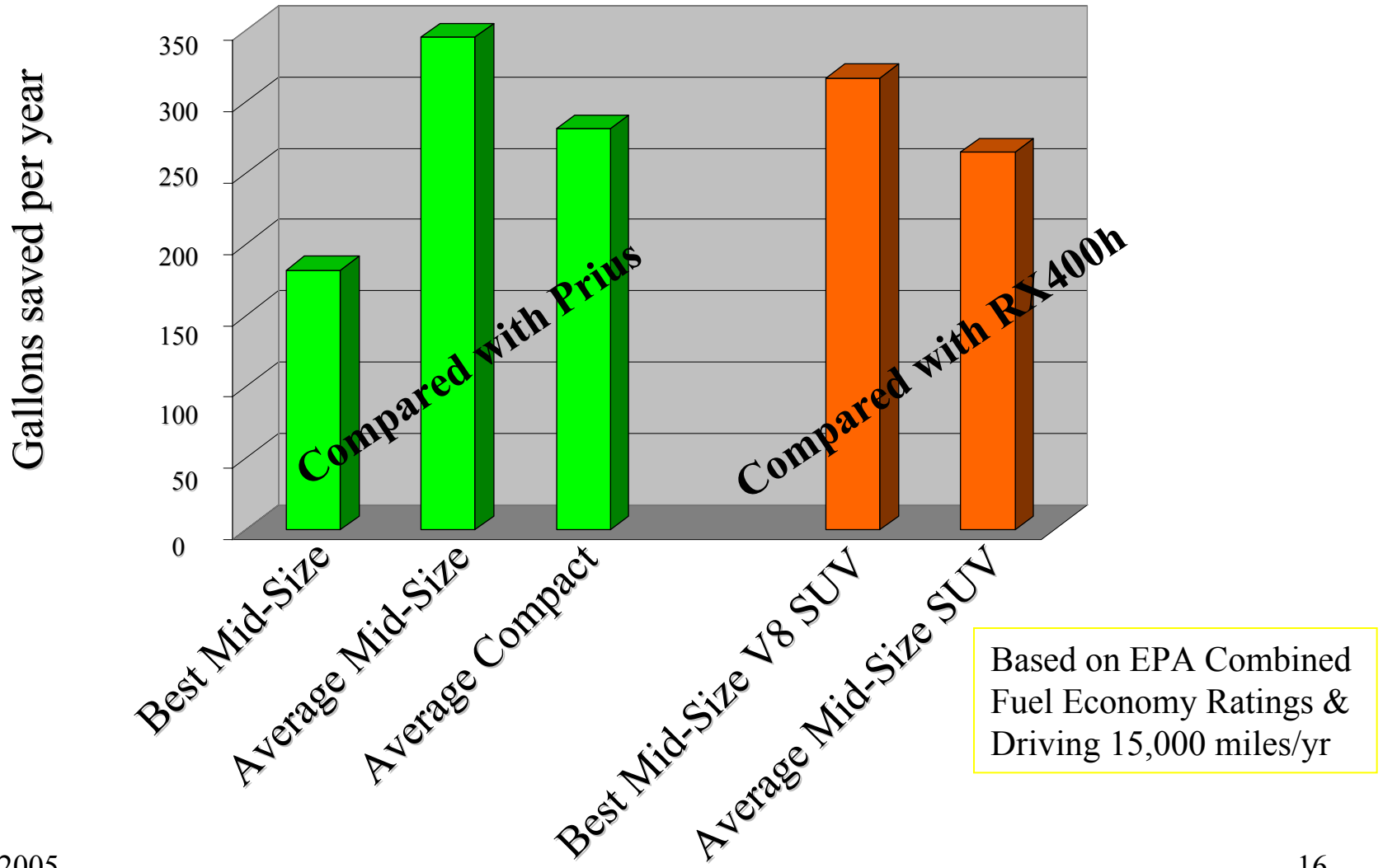

Fuel Cells, The Next Step?

- **Why** – Hydrogen-fueled fuel cell vehicles have the potential to remove the automobile from the environmental equation
 - Zero tailpipe emissions
 - Potential for low / zero carbon hydrogen
 - Non-petroleum based fuel source
- **When**
 - Attributes meet or exceed conventional vehicles at a **reasonable cost**
 - Society is prepared – infrastructure, codes & standards
 - There is a compelling reason for the customer to change
- **Who** – the auto industry is addressing the vehicle
 - Governments and other industries must participate

Toyota FCHV

12 currently
operating in
California



- 4-door, 5-passenger Highlander based SUV
- 90 kW Toyota PEM stack
- Hybrid drive system – similar to RX400h
- Compressed H₂ at 5000 psi - ZEV
- 96 mph top speed
- 188 mile range
- Over 55,000 miles of experience in US

Issues of FCV Mass Introduction

Red = Greatest Challenge

Items	Challenges	Responsibility
Technical	Low temperature, High temperature, High Efficiency, Size reduction, Reliability, Durability, High-altitude, EMI, etc.	Vehicle Manufacturers
Marketability	Vehicle cost, Range (Hydrogen storage)	
Environment	Recyclability, Life Cycle Assessment (LCA)	
Safety	Hydrogen, High voltage, Crash worthiness	Government, Energy Supplier
Infrastructure	Hydrogen production, transportation & storage Infrastructure development & hydrogen cost	

Low Temperature Performance

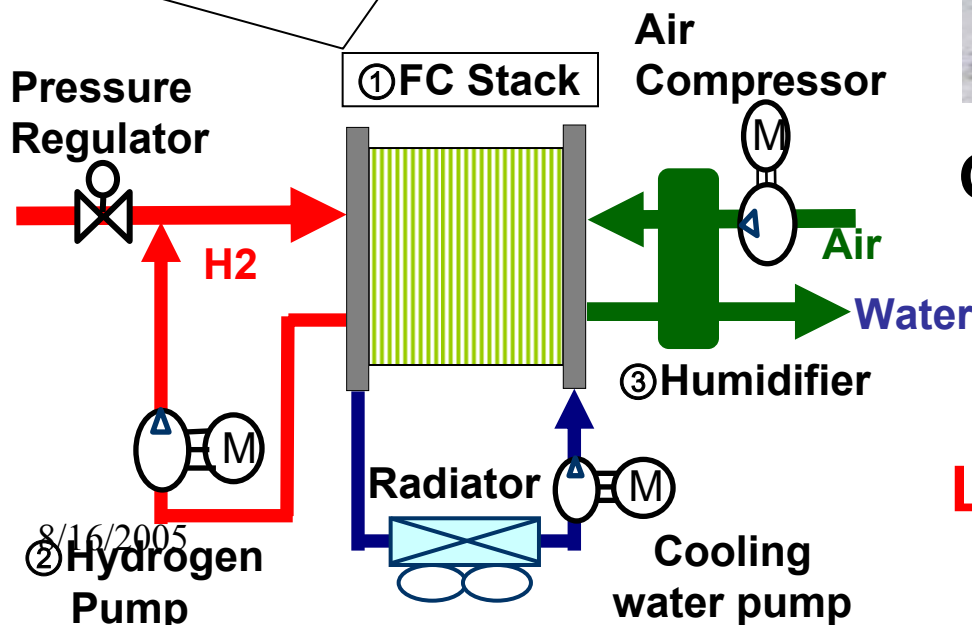
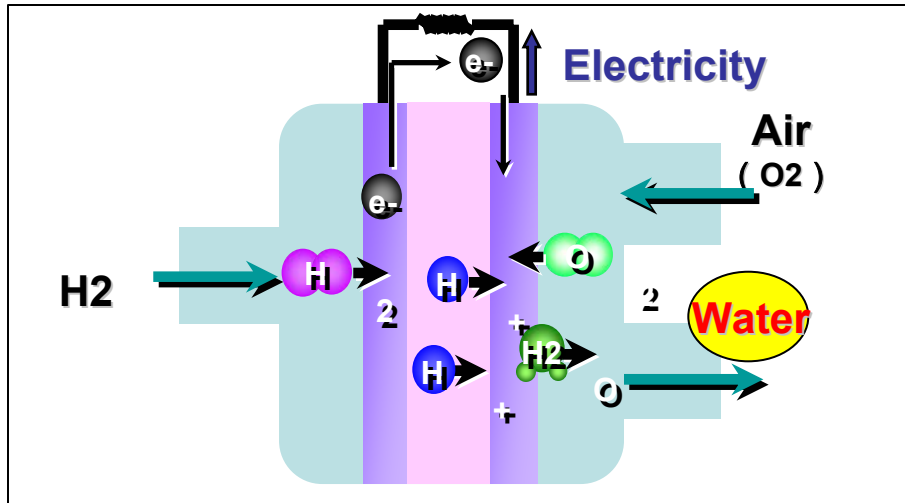

Generated water freezes in FC stack and auxiliary components

Low temperature start up is one of the major issues

Reduction of Precious Metal Catalyst

Current worldwide demand for platinum : about 187 tons / year. *1

Demand for automotive catalyst : about 90 tons / year.*1

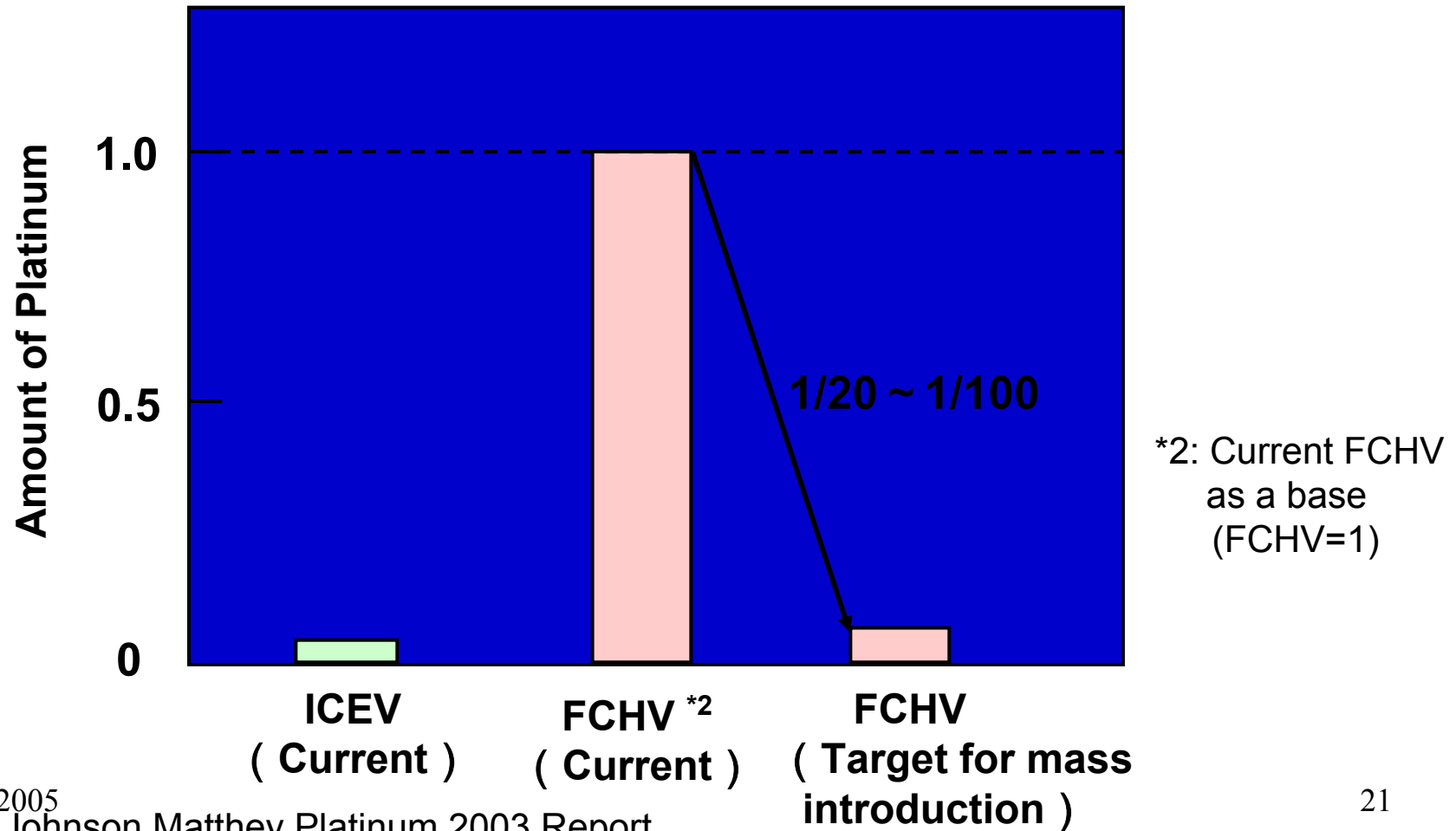

Hydrogen Storage Technology

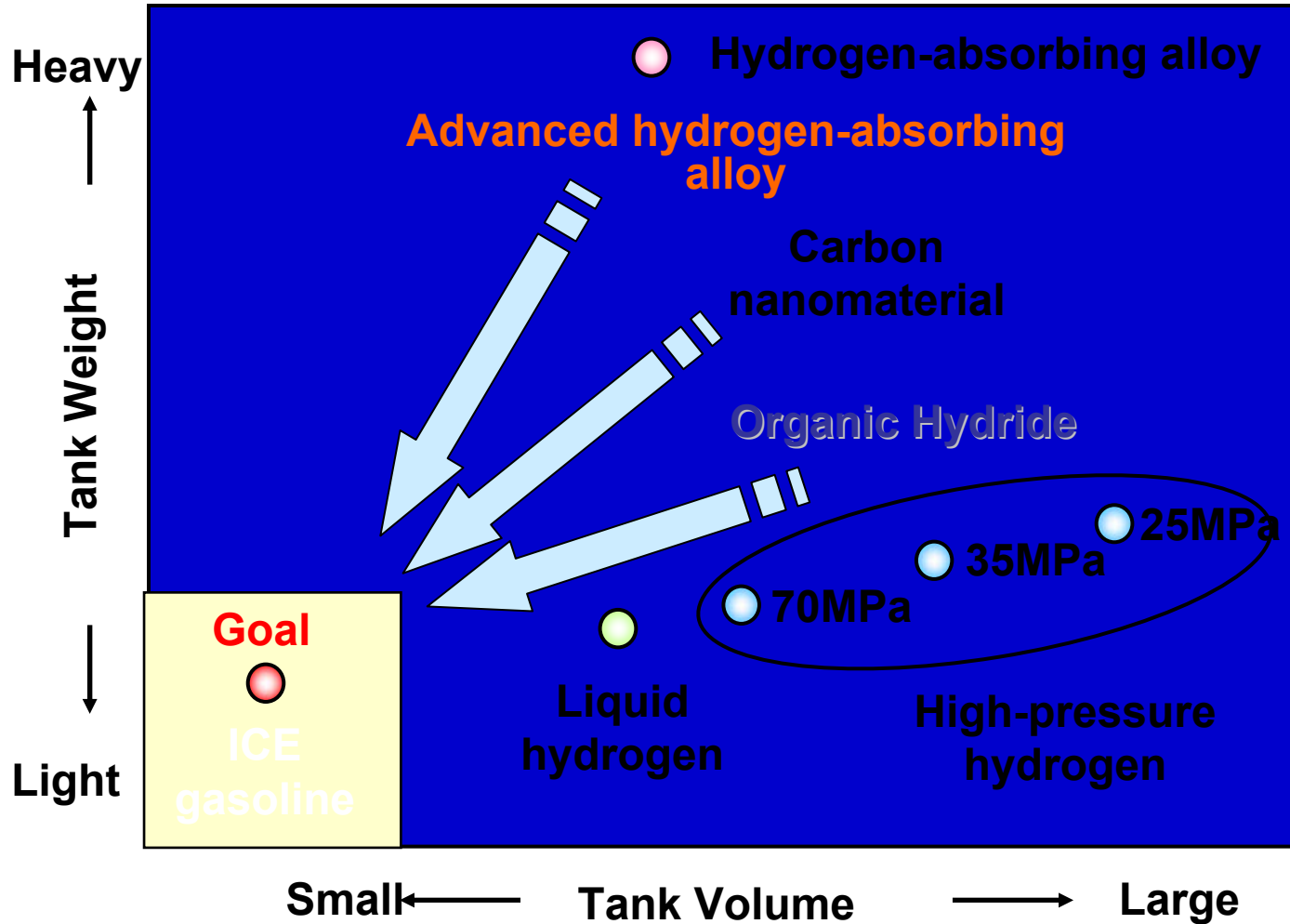

Range (Hydrogen Storage)

High pressure hydrogen



Issues: Volume

Hydrogen-absorbing alloy



Weight

Liquid hydrogen

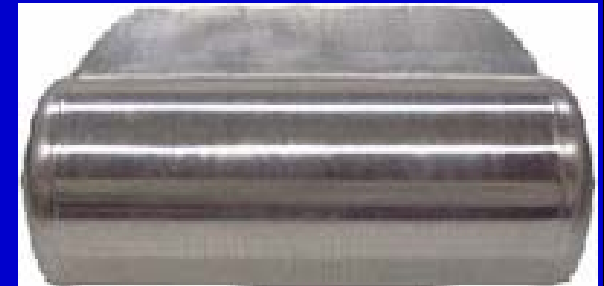

Boil-off gas

Carbon nanotubes

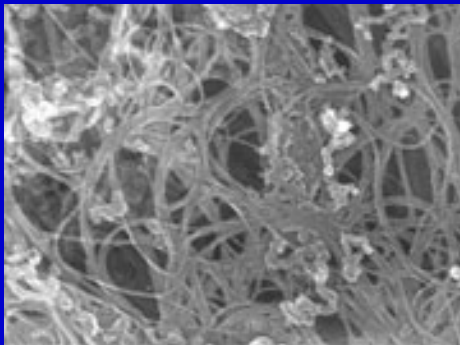

Issues: Actual storage capability?

Chemical hydrides

NaBH_4



Decalin($\text{C}_{10}\text{H}_{18}$) Naphthalene(C_{10}H_8)



- H_2
Catalyst
+ H_2



Collecting / Recycling

Vital factor for Marketing FCV = Range

Innovative hydrogen storage technology needed.

(1) Comparison of fuel amounts

(2) Comparison of range

Gasoline equivalent
0 20 40 60 80 100 (L)

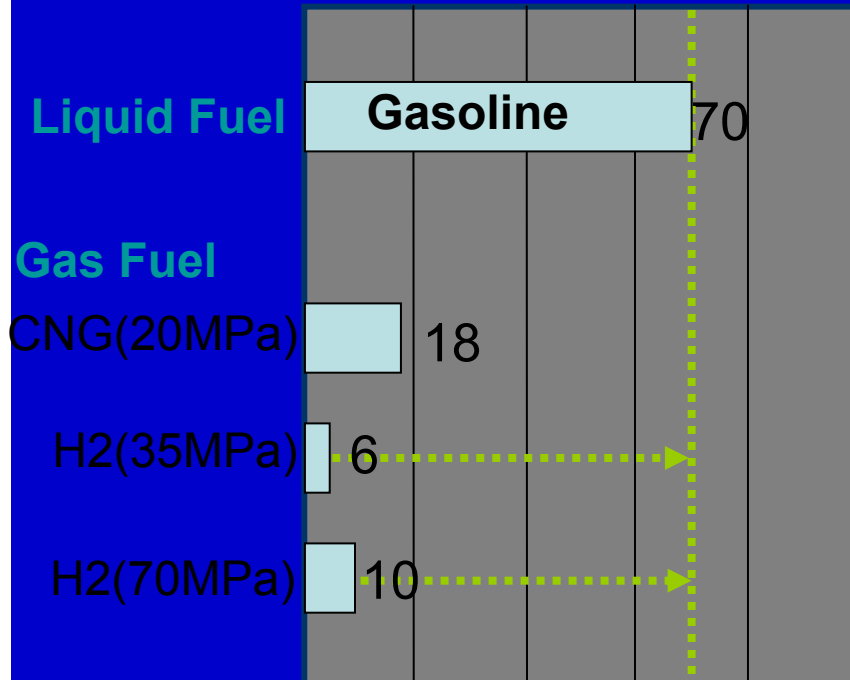

(Tank capacity of 70L)

0 500 km

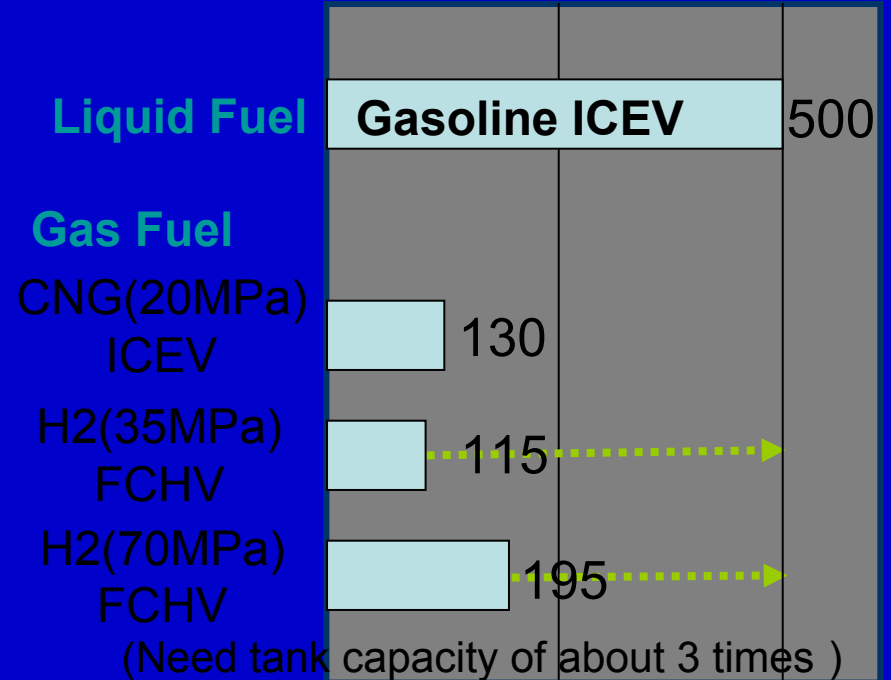

(Need tank capacity of about 3 times)

(Tank capacity of 70L)

Well to Wheel Efficiency Comparison

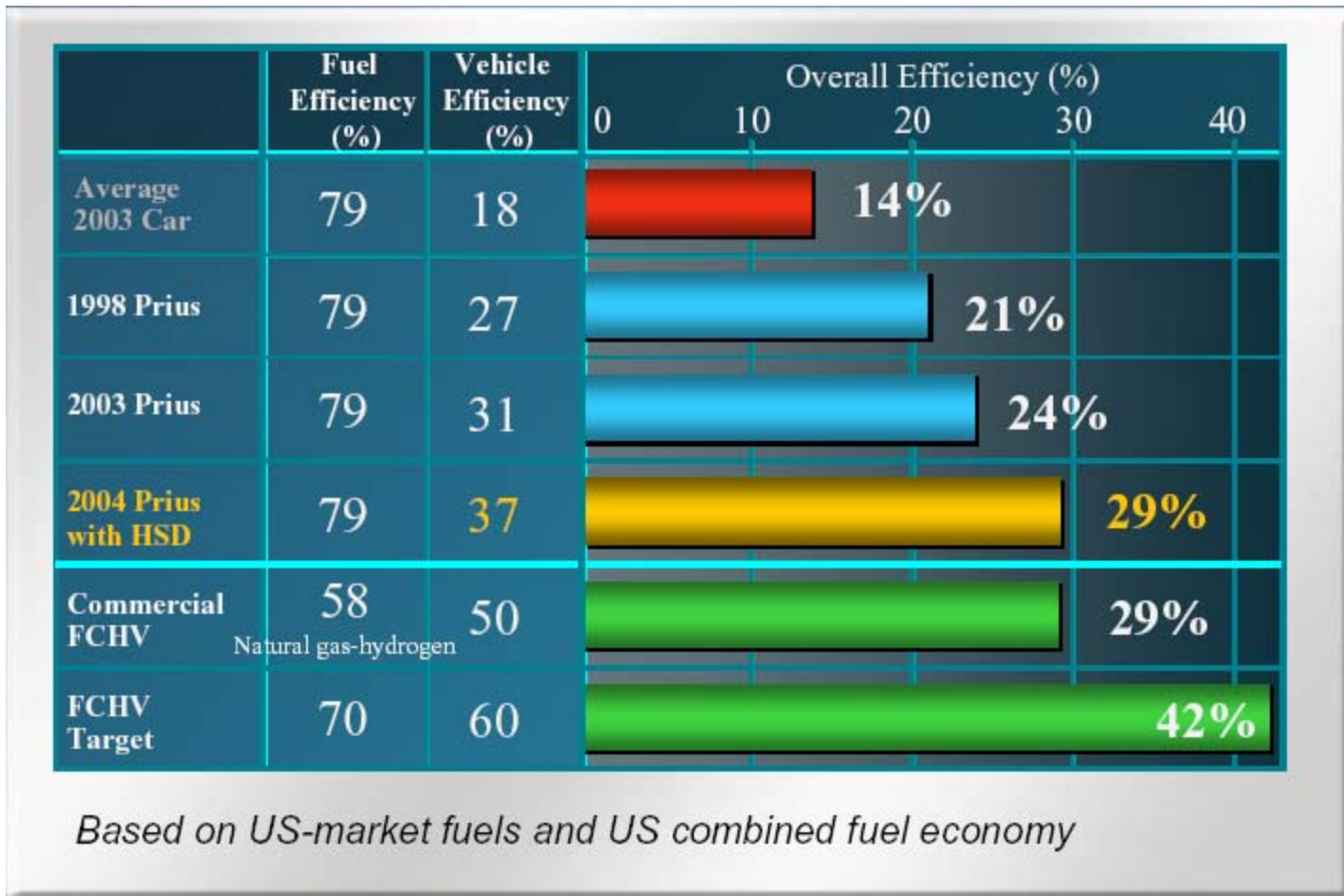

Well to Wheels CO₂ Comparison

- Today's latest generation hybrids compare favorability to H₂ fueled FCVs

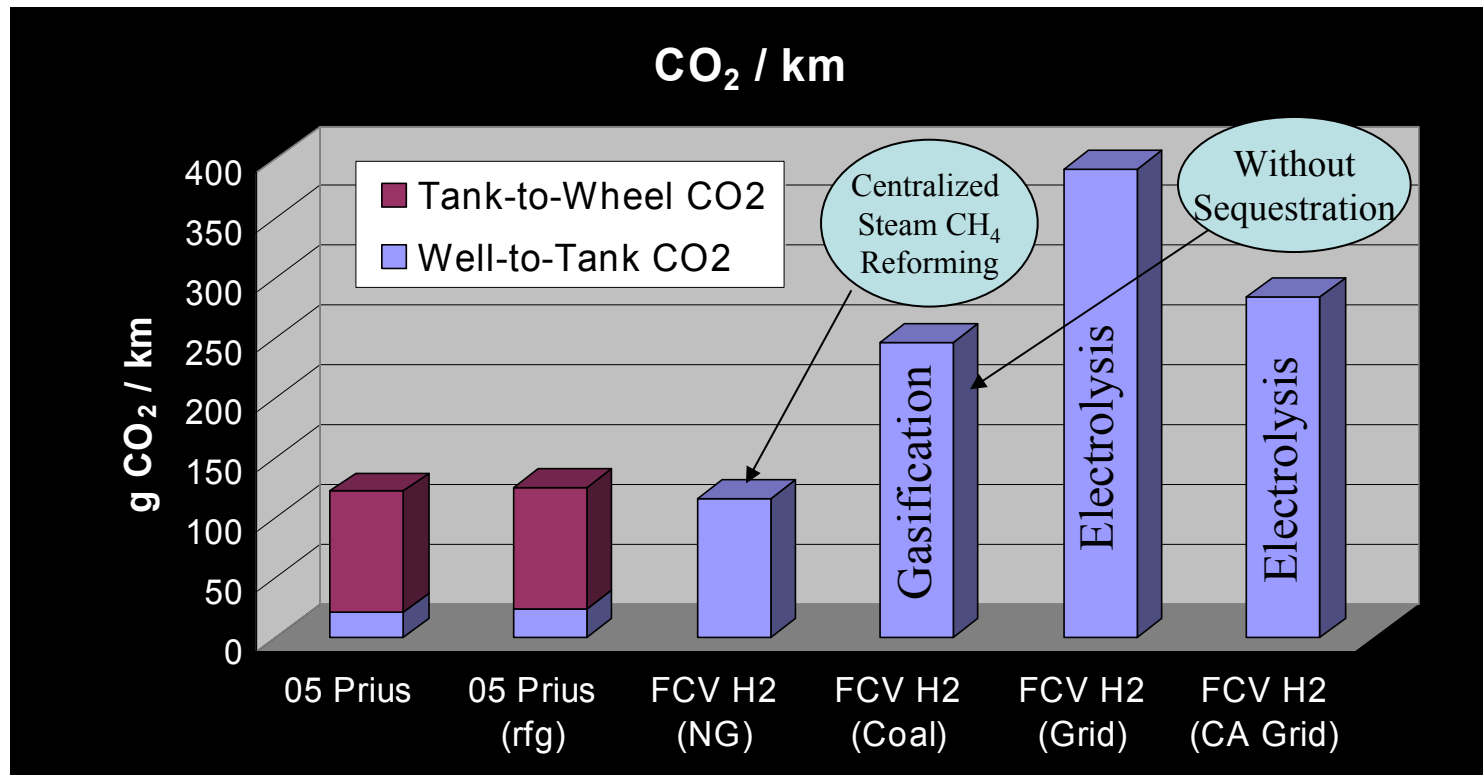

Conclusions

Sustainable Mobility

Long-Term - Needs Major Breakthroughs

CNGHV **D-HV** **G-HV** **FCHV**

Hybrid Technology

Viable for the Foreseeable Future

D-Cat **D-4**
CNG **Diesel DI** **Lean Burn** **EV**
VVT-i

Core Toyota Technology

Challenges in the US

Alternative Fuel

Diesel Engine

Gasoline Engine

Electric Vehicle

Thank You!

